



MINISTRY OF EDUCATION, SINGAPORE
in collaboration with
CAMBRIDGE ASSESSMENT INTERNATIONAL EDUCATION
General Certificate of Education Ordinary Level

SCIENCE (PHYSICS, BIOLOGY)

5087/01

Paper 1 Multiple Choice

For examination from 2024

SPECIMEN PAPER

1 hour

Additional Materials: Multiple Choice Answer Sheet



READ THESE INSTRUCTIONS FIRST

Write in soft pencil.

Do not use staples, paper clips, glue or correction fluid.

Write your name, Centre number and index number on the Answer Sheet in the spaces provided unless this has been done for you.

DO NOT WRITE ON ANY BARCODES.

There are **forty** questions on this paper. Answer **all** questions. For each question there are four possible answers **A, B, C** and **D**.

Choose the **one** you consider correct and record your choice in **soft pencil** on the separate Answer Sheet.

Read the instructions on the Answer Sheet very carefully.

Each correct answer will score one mark. A mark will not be deducted for a wrong answer.

Any rough working should be done in this booklet.

The use of an approved scientific calculator is expected, where appropriate.

This document consists of **17** printed pages and **1** blank page.



Singapore Examinations and Assessment Board



Cambridge Assessment
International Education

- 1 A student uses a stopwatch to time a runner running around a circular track. The runner runs two laps (twice around the track).

The diagrams show the readings on the stopwatch when the runner starts running, at the end of the first lap, and at the end of the second lap.



reading when runner starts



reading at end of first lap



reading at end of second lap

What is the time taken for the runner to run the second lap?

- A** 0min 50s **B** 1min 10s **C** 1min 13s **D** 2min 03s
- 2 A student measures the velocity of a trolley travelling in a straight line. At one instant, the velocity of the trolley is 1.0 m/s and 2.0 s later the velocity is 4.0 m/s.

What is the acceleration of the trolley?

- A** 1.5 m/s² **B** 2.0 m/s² **C** 2.5 m/s² **D** 5.0 m/s²
- 3 A passenger is sitting in an aeroplane which takes off and climbs to 10 000 m in a certain time.

During this time what happens to the mass and to the weight of the passenger?

	mass	weight
A	decreases	decreases
B	increases	increases
C	unchanged	decreases
D	unchanged	increases

- 4 What are the conditions for equilibrium?

	resultant force acting	resultant turning effect acting
A	no	no
B	no	yes
C	yes	no
D	yes	yes

- 5 To prevent a cement mixer sinking into soft ground, the mixer is placed on a large flat board.

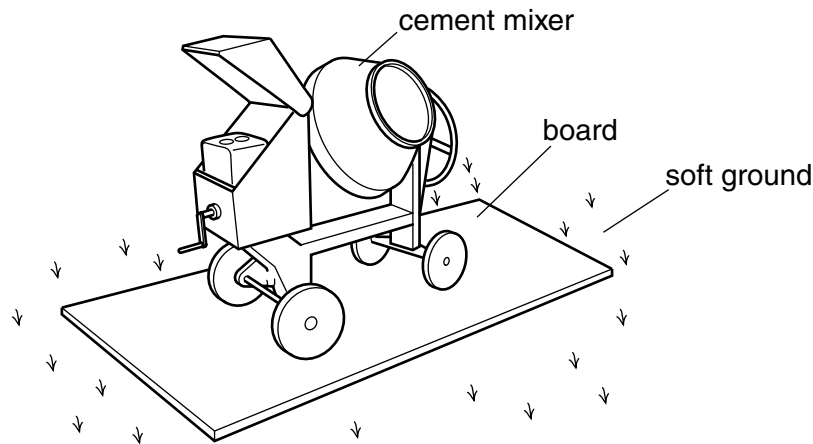

Why does this prevent the mixer sinking?

- A The large area decreases the pressure on the ground.
 - B The large area increases the pressure on the ground.
 - C The large area decreases the weight on the ground.
 - D The large area increases the weight on the ground.
- 6 A bungee jumper has jumped from a bridge and falls with increasing speed before the cord begins to extend.

What is the principal energy transfer taking place during this period?

- A kinetic store to gravitational potential store
 - B kinetic store to internal store
 - C gravitational potential store to kinetic store
 - D gravitational potential store to internal store
- 7 A man weighs 600 N. He runs up a staircase of total height 4.0 m in 3.0 s.
- How much power is needed to do this?
- A 450 W
 - B 800 W
 - C 2400 W
 - D 7200 W

- 8 A quantity of gas is trapped in a container by a frictionless piston.

The temperature of the gas is raised.

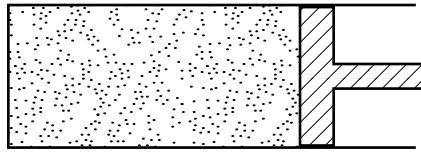

Which statement is correct?

- A The gas expands.
 - B The molecules get larger.
 - C The piston remains in the same place.
 - D The speed of the molecules decreases.
- 9 The dipper in a ripple tank vibrates at a frequency of 4.0 Hz and the resulting wave pattern is photographed.

The distance between the two crests shown is 20 cm.

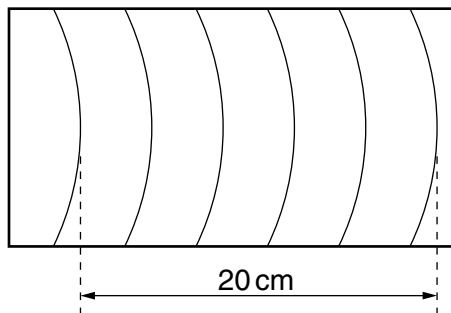

What is the speed of the wave?

- A 4.0 cm/s
 - B 5.0 cm/s
 - C 16 cm/s
 - D 20 cm/s
- 10 Which group contains only transverse waves?
- A infrared waves, light waves, sound waves
 - B infrared waves, light waves, ultraviolet waves
 - C infrared waves, ultraviolet waves, sound waves
 - D light waves, sound waves, ultraviolet waves

- 11 A radio wave has a wavelength of 1500 m and travels with a speed of 3.0×10^8 m/s.

What is the radio wave's frequency?

- A 5.0×10^2 Hz
 B 4.5×10^3 Hz
 C 2.0×10^5 Hz
 D 2.0×10^6 Hz
- 12 A hospital needs to sterilise medical equipment.

Which electromagnetic waves could be used?

- A infrared
 B microwaves
 C radio waves
 D ultraviolet
- 13 The current in an electric heater is 10A. It is switched on for 5 minutes.

How much charge flows through the heater?

- A 0.5 C B 2 C C 50 C D 3000 C
- 14 A circuit contains two resistors connected in parallel with a battery.

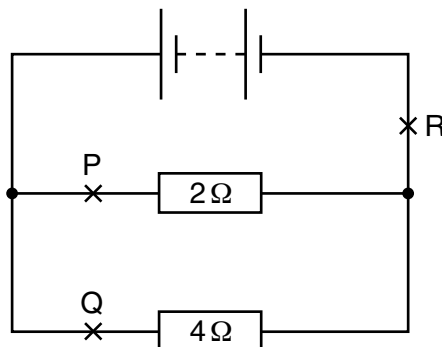

Which of the following statements about the currents at P, Q and R is correct?

- A The current at P is the greatest.
 B The current at Q is the greatest.
 C The current at R is the greatest.
 D The current is the same at points P, Q and R.

- 15 The diagram shows a circuit.

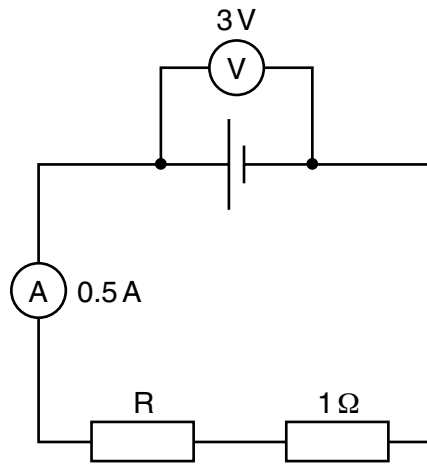

The ammeter has negligible resistance.

What is the resistance of the resistor R?

- A** 0.5Ω **B** 1.5Ω **C** 5Ω **D** 6Ω
- 16 An electric heater is rated at 3kW. The consumer is charged 20 cents per kWh of energy transferred electrically from the mains supply.

What is the cost of using the heater for 5 hours?

- A** 12 cents **B** 60 cents **C** 100 cents **D** 300 cents
- 17 Many electrical appliances have metal cases.

To prevent the case from becoming 'live', with the possibility of an electric shock, the earth wire of the electric cable is attached to the case.

How does the earth wire prevent an electric shock?

- A** It allows a current to flow to earth, so that the appliance continues working.
B It allows a large current to flow to earth, blowing the fuse.
C It prevents the fuse from blowing.
D It reduces the current to a safe level.

- 18 Four plotting compasses are placed in the magnetic field of two identical bar magnets as shown in the diagram.

Which compass is shown pointing in the **wrong** direction?

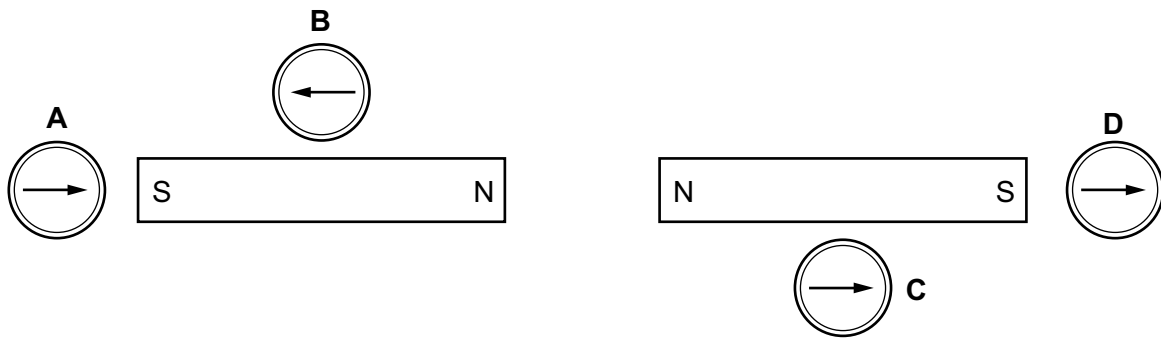

- 19 Two parallel vertical wires P and Q are a small distance apart in air. There is a downwards electric current in both wires. A force acts on Q owing to the current in P. This force is perpendicular to the wire Q.

What is the direction of the force on Q?

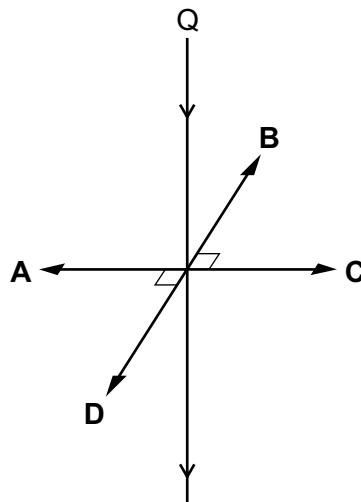

- 20 The half-life of the nuclide radium-225 is 15 days. A pure sample of this nuclide has a mass of 16g. How long will it be before the mass of radium-225 in the sample is 2.0g?
- A 45 days
 B 60 days
 C 105 days
 D 120 days

21 The diagram shows a plant cell as seen under a light microscope.

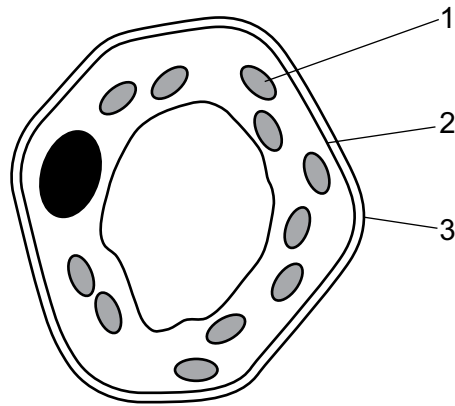

What are the functions of the numbered parts in the cell?

	control of entry of substances	synthesis of carbohydrates
A	1	3
B	2	1
C	3	2
D	3	1

22 The table shows the main functions of red blood cells and root hair cells.

Which row is correct?

	red blood cells	root hair cells
A	absorption	absorption
B	absorption	transport
C	transport	absorption
D	transport	transport

23 An experiment was carried out to determine the effect of sucrose concentration on the mass of potato pieces. Identical pieces of potato were placed in sucrose solutions of different concentrations. After three hours, the mass of each potato piece was measured.

Which graph best shows the results of this experiment?

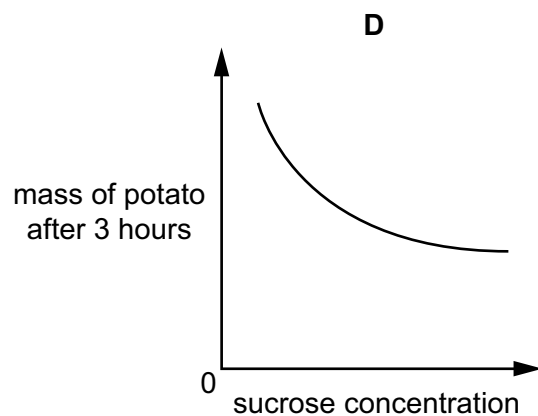
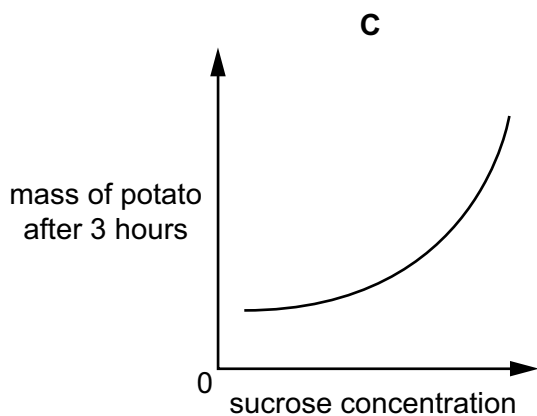
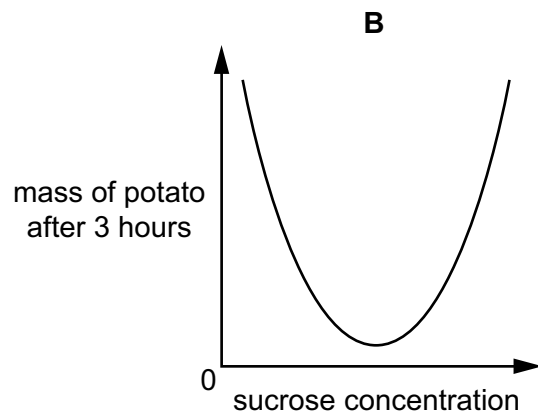
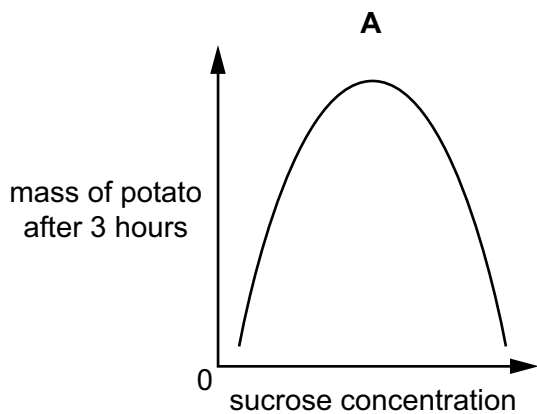

- 24 A sample of food mixed with water is tested to find out its contents. The results are shown in the table.

test	result
iodine solution added	yellow colour
Benedict's solution is added and the mixture is heated	red precipitate
shaken with ethanol and water	white emulsion
biuret test	blue colour

Which nutrient or nutrients are present in the food?

- A fat and reducing sugar
 - B fat and starch
 - C protein
 - D reducing sugar only
- 25 Which word completes the sentence?

In humans, large, insoluble molecules have to be digested before they can be

- A absorbed
- B egested
- C ingested
- D transpired

26 The diagram shows the human digestive system.

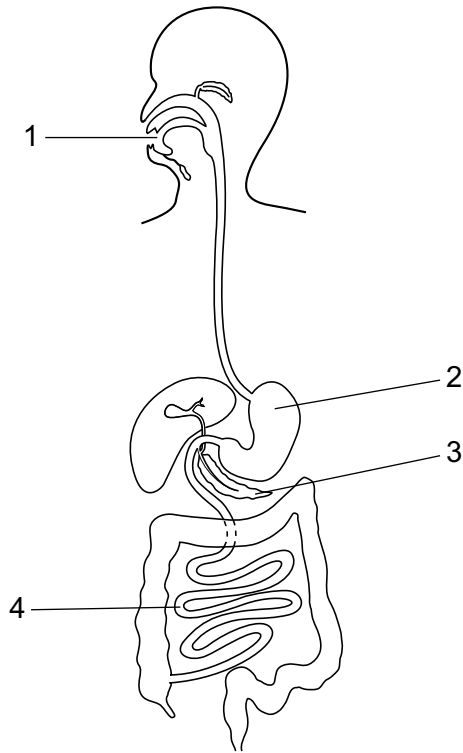

In which regions does amylase act?

- A 1 and 3
- B 1 and 4
- C 2 and 3
- D 2 and 4

27 The diagram shows an investigation of blood flow in the veins of the lower arm.

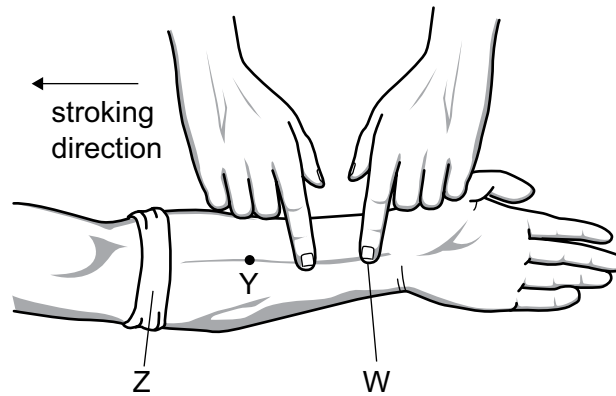

A cloth is tightly wrapped round the arm at point Z and the veins in the lower arm bulge clearly. One finger then presses on one of these veins at W.

When another finger strokes the vein in the direction shown in the diagram, the vein lies flat between points W and Y.

Some possible explanations are listed.

- 1 The bandage at Z prevents backflow of blood.
- 2 The finger pressed at W prevents more blood entering the vein.
- 3 A valve at Y prevents backflow.
- 4 A valve at Z prevents more blood from entering the vein.

Which explanations about why the vein lies flat are correct?

- A** 1 and 2 **B** 1 and 4 **C** 2 and 3 **D** 2 and 4

28 The diagram shows a section through the heart.

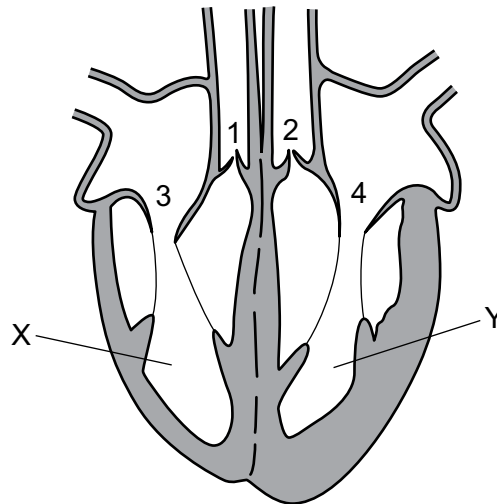

While blood is leaving chambers X and Y, which valves are open and which are closed?

	valves 1 and 2	valves 3 and 4
A	closed	closed
B	closed	open
C	open	closed
D	open	open

29 Fitness training increases the concentration of lactic acid that runners can tolerate in their muscles.

What is happening in the muscles of these runners?

- A** Aerobic respiration in the muscles occurs more quickly.
- B** Blood flow to the muscles is decreased.
- C** More anaerobic respiration takes place in the muscles.
- D** More carbon dioxide is released by the muscles.

30 Which is a common symptom of **both** influenza and pneumococcal disease?

- A** fever
- B** nausea
- C** runny nose
- D** skin rash

- 31 Vaccines contain an agent that resembles a pathogen and prevent infectious diseases by stimulating**S**..... to quickly produce**T**..... when the pathogen invades.

Which row contains the correct words to fill the gaps **S** and **T**?

	S	T
A	red blood cells	antibiotics
B	red blood cells	antibodies
C	white blood cells	antibiotics
D	white blood cells	antibodies

- 32 The diagram shows the arrangement of cells in the leaf of a green plant.

In which region do the cells contain the greatest number of chloroplasts?

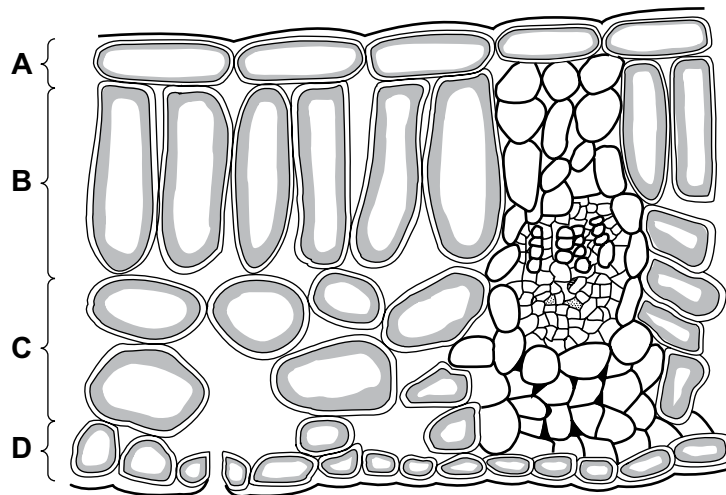

- 33 Which substances are transported in the phloem and in the xylem?

	phloem	xylem
A	amino acids and water	amino acids and mineral ions
B	starch and mineral ions	mineral ions and sucrose
C	sucrose and amino acids	mineral ions and water
D	sucrose and starch	starch and water

34 Some organisms live in the dark at the bottom of the seas and, to synthesise glucose, use energy from chemicals in the very hot water that comes out of volcanoes.

Which statement best describes these organisms?

- A Their enzymes are easily denatured by heat.
- B They do not contain chlorophyll.
- C They obtain energy only through feeding on other organisms.
- D They synthesise glucose through photosynthesis.

35 The diagram represents the flow of substances within a balanced ecosystem.

The boxes are various trophic levels.

Which box represents decomposers?

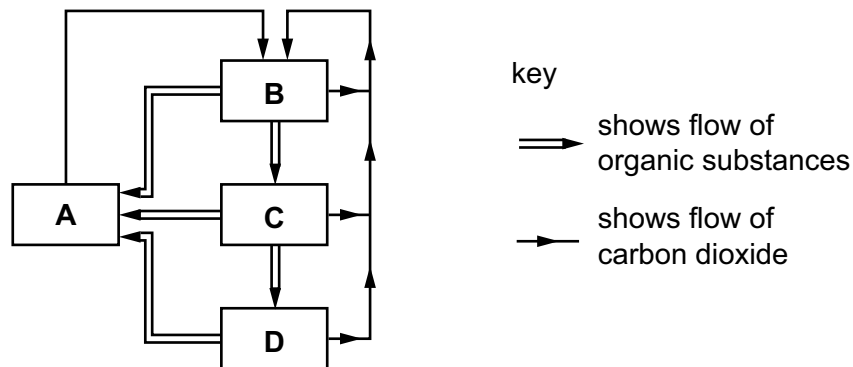

36 The diagram shows a food web in a tropical forest.

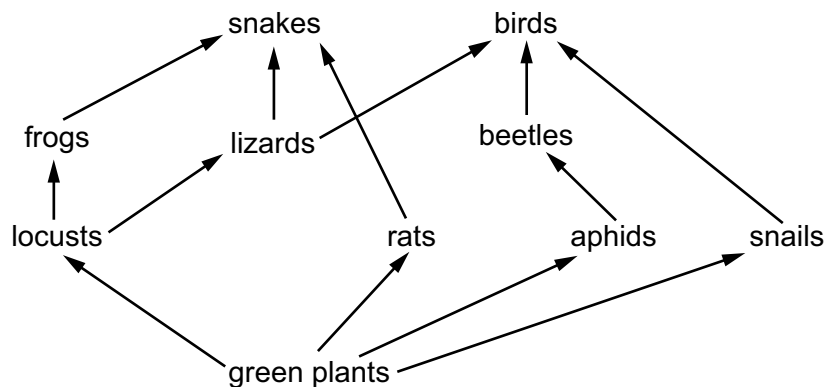

At which trophic level are the lizards in this food web?

- A decomposers
- B primary consumers
- C producers
- D secondary consumers

37 Which statement about chromosomes is correct?

- A Chromosomes are long DNA molecules called genes which are divided into sections.
- B Chromosomes include a long molecule of DNA divided into sections called genes.
- C Genes are divided into sections called chromosomes.
- D Genes include long DNA molecules called chromosomes.

38 The diagram below shows a section of DNA.

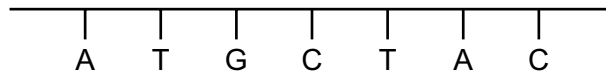

Which row has the correct complementary DNA base sequence?

- A TACCATG
- B GCATCGT
- C TACGATG
- D CGTAGCA

39 The diagram shows the changes in the thickness of the uterus lining of a woman during her menstrual cycle.

At which time would a fertilised egg implant?

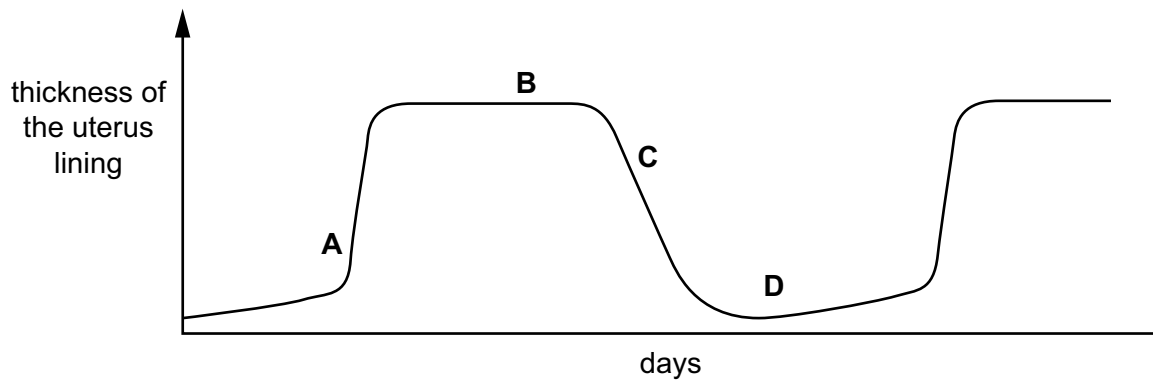

40 The diagram shows the sex determination of offspring in humans.

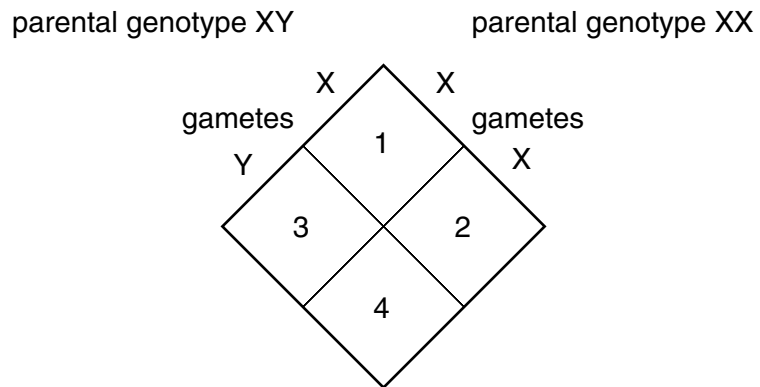

Which sexes are the offspring in boxes 1, 2, 3 and 4?

	1	2	3	4
A	male	female	male	female
B	male	female	female	male
C	female	male	female	male
D	female	female	male	male

Permission to reproduce items where third-party owned material protected by copyright is included has been sought and cleared where possible. Every reasonable effort has been made by the publisher (UCLES) to trace copyright holders, but if any items requiring clearance have unwittingly been included, the publisher will be pleased to make amends at the earliest possible opportunity.

Cambridge Assessment International Education is part of Cambridge Assessment. Cambridge Assessment is the brand name of the University of Cambridge Local Examinations Syndicate (UCLES), which is a department of the University of Cambridge.